

Installation Instructions for Air LED Suspension

IMPORTANT INFORMATION

- This product is ETL listed for indoor locations.
- This product can **ONLY** be ceiling mounted.
- This product can mount to either a 4" square electrical box with round plaster ring or an octagon electrical box.

SAVE THESE INSTRUCTIONS!



Install the Fixture

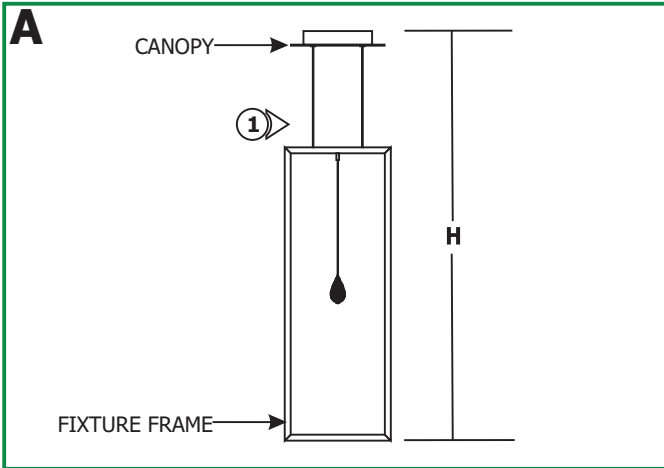

1: Determine the desired fixture height (**H**), from the bottom of the fixture frame to the top the canopy.

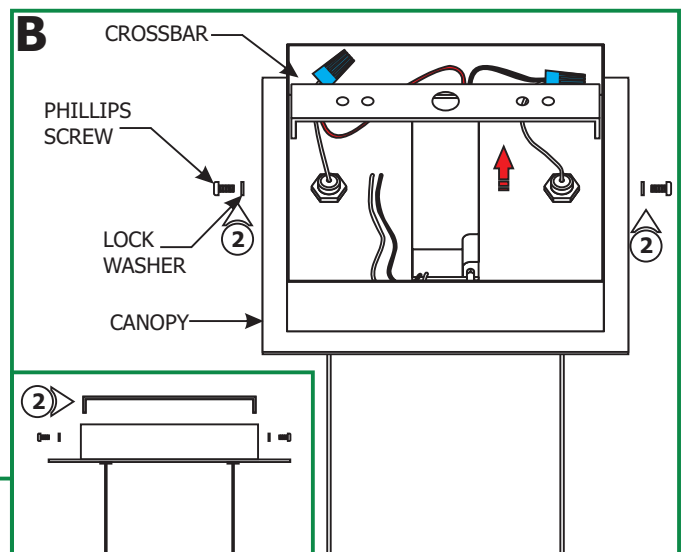

2: Remove the two Phillip screws and lock washers on the sides of the canopy, and carefully pull the crossbar out.

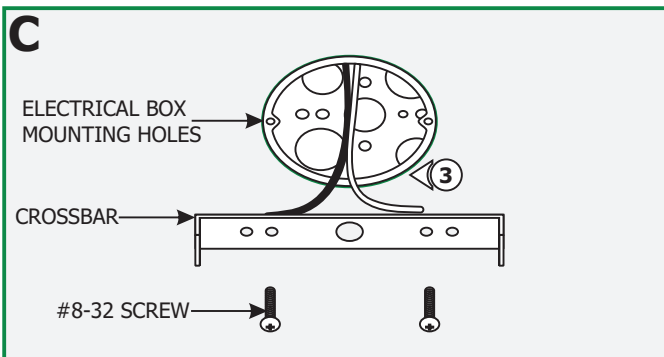

3: Mount the crossbar to the electrical box holes with the provided #8-32 screws.

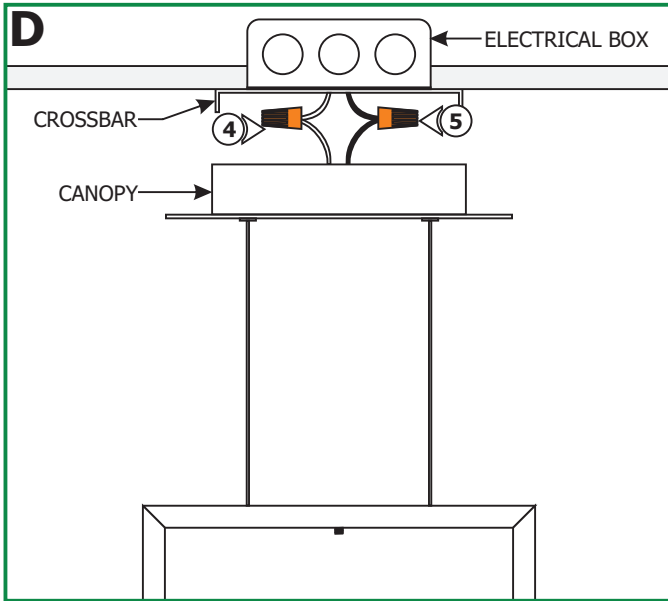

NOTE: It is recommended that one person holds the canopy while the electrician installs it.

- 4:** Connect the white LED driver wire to the neutral power wire with a wire nut.
- 5:** Connect the black LED driver wire to the hot power wire with a wire nut.

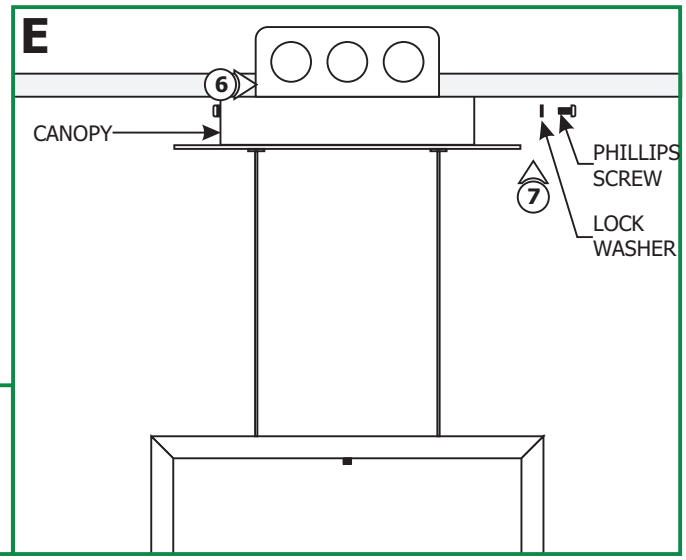

- 6:** Place all wires and wire nut connections inside the electrical box.
- 7:** Mount the canopy to the crossbar with the two Phillips screws and lock washers.

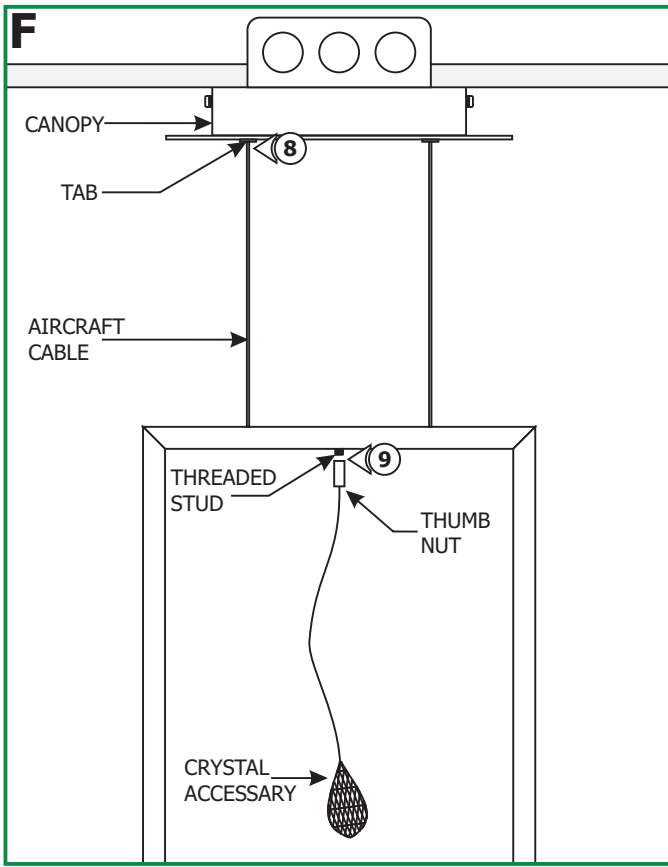

- 8:** To make any minor adjustments to the fixture height, push the tabs on the canopy to slide the fixture frame up and down until the desired height is achieved. Release the tab to lock the aircraft cable in place.
 - 9:** Secure the crystal accessory to the fixture frame by tightening the thumb nut to the threaded stud.
- NOTE:** The fixture contains integrated LED lamps rated for 50,000 hours. It consumes a total of **14** watts.