

Installation Instructions for **Fast Jack Drop Pendant**

IMPORTANT SAFETY INSTRUCTIONS

To reduce the risk of fire, electrical shock, exposure to excessive UV radiation, or injury to persons:

- Use this fixture indoors only.
- Do not look directly at the lamp while the fixture is on.
- **RISK OF FIRE:** Use only the type of lamp and maximum wattage indicated in this instruction manual.
- Never cover the halogen lamp with anything other than a lamp shield provided by Edge Lighting and never place flammable material close to the fixture.
- Never turn the fixture on and off by connecting and disconnecting the halogen lamp.
- Do not touch the fixture head, shade or lamp shield while the fixture is on. These surfaces may be **VERY HOT**.
- Do not touch lamp at anytime. Use a soft cloth instead as oil from skin may damage lamp.
- It is normal for a new halogen lamp to produce minor smoke when first turned on.
- Do not operate the luminaire with a missing or damaged shield.
- Turn power off and allow to cool before replacing lamp.



IMPORTANT INFORMATION

- This product is ETL listed for indoor dry locations and approved to be used at any height above the finished floor.

SAVE THESE INSTRUCTIONS!

Install the Lamp and Shade

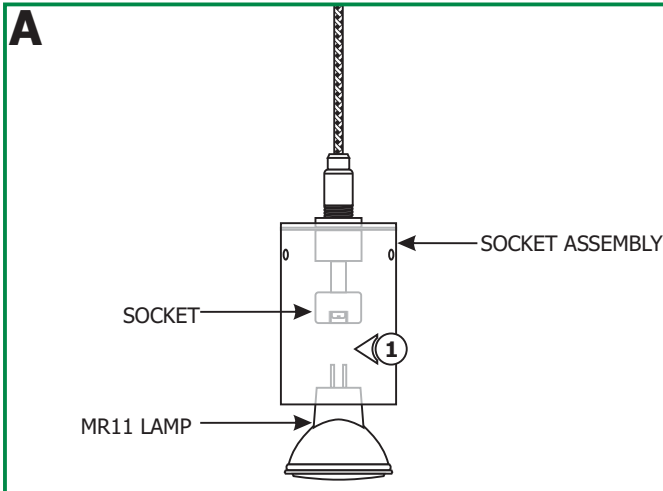

CAUTION: To reduce risk of a burn or electrical shock during lamping, disconnect the power to the fixture.

Use **MAX 20** Watt, Type MR11 Front Glass Cover Halogen Lamp.



1: Push the lamp pins completely into the socket holes.

OPTIONAL: Fill 1" of the glass shade with water for a different light effect. Do not use flammable liquids. Water must be changed once a month.

2: Place the glass shade completely over the socket assembly.

3: Align the socket assembly holes to the glass shade holes. While holding the glass shade in place, secure it by tightening the two thumb screws with plastic washers.

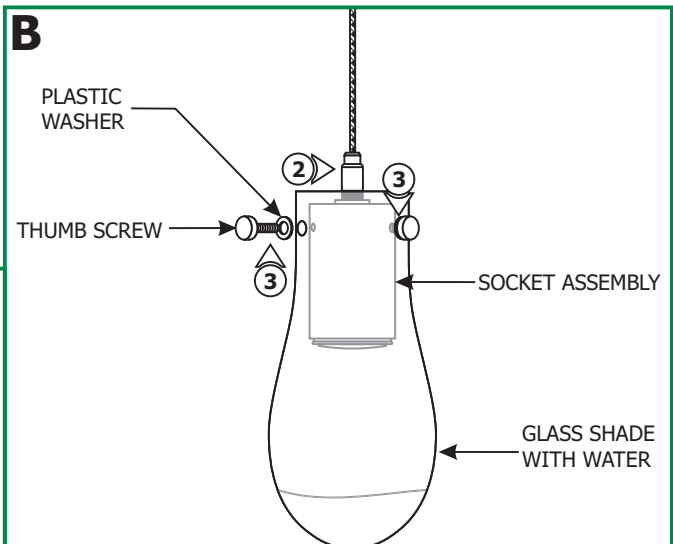

Adjust the Fixture Height

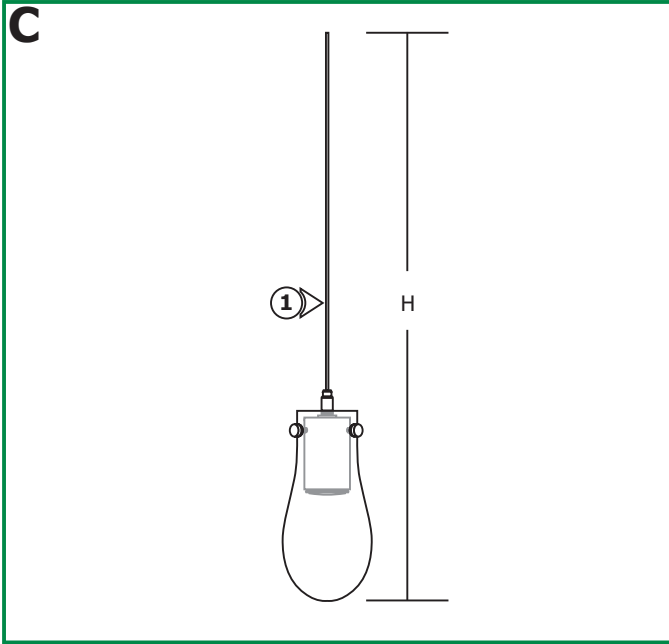

1: Cut the coaxial cable to the desired length (H) with a sharp cutter. The overall fixture height is measured from the bottom of the glass shade to the end of the coaxial cable.

2: Loosen the M4 set screw on base of the coaxial fixture connector with the 4mm Allen wrench provided. **Do not remove this set screw.**

3: Remove the M3 set screw on tip of the connector with the 3mm Allen wrench provided.

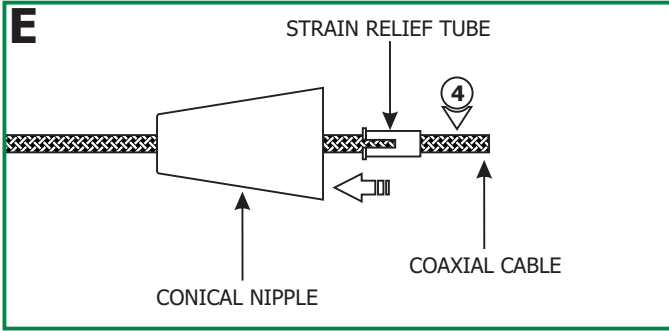
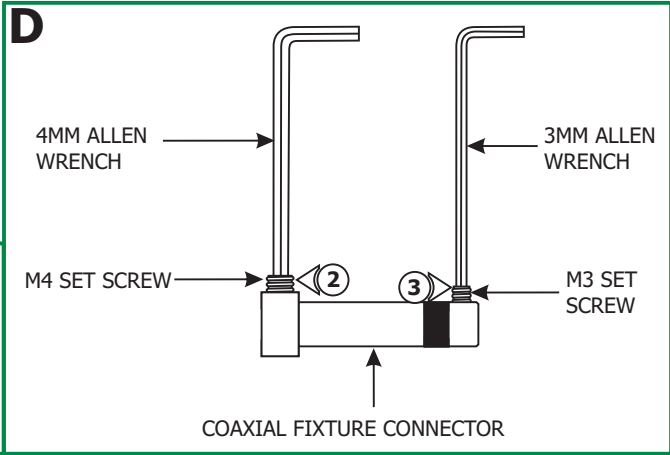

4: Feed the coaxial cable through the conical nipple and flared side of the strain relief tube. Slide the conical nipple and strain relief tube down the coaxial cable.

5: Feed the coaxial cable into the coaxial fixture connector. The coaxial cable will come to a stop point.

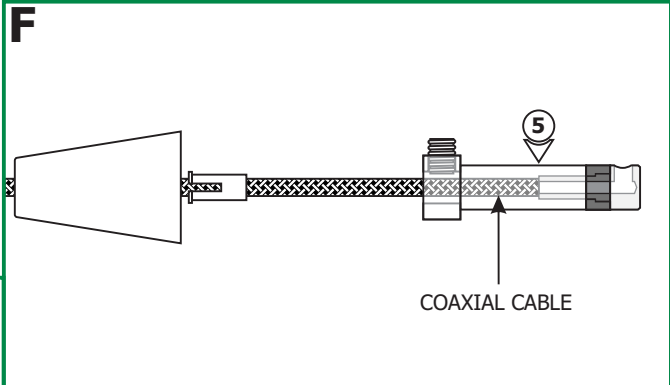

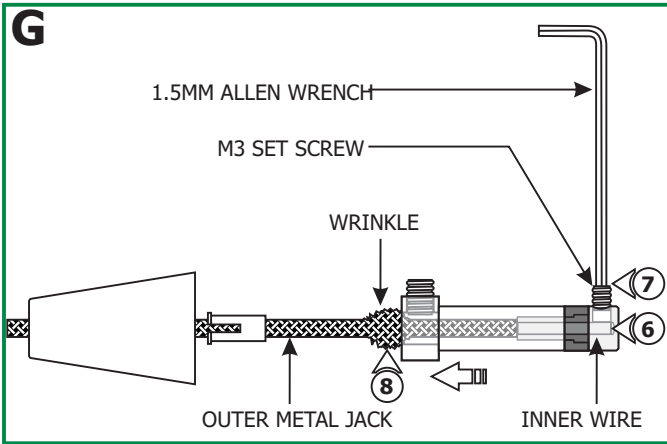

6: Keep feeding the coaxial cable in until the inner wire is visible in the screw hole of the fixture connector tip. The outer metal jacket will start to wrinkle.

7: Hold the fixture connector in place. Replace and tighten the M3 set screw on fixture connector tip with the 1.5mm Allen wrench.

8: Pull down the outer metal jacket to smooth the wrinkles.

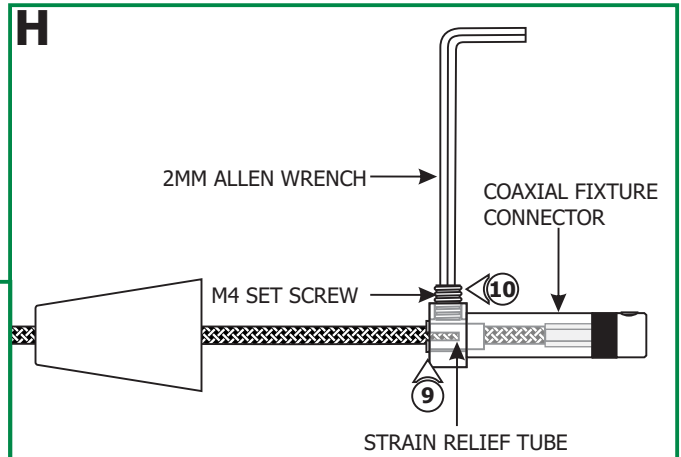

9: Push the strain relief tube completely into the coaxial fixture connector. Make sure the slot on the strain relief tube is not inline with the M4 set screw.

10: Tighten the M4 set screw with the 2mm Allen wrench.

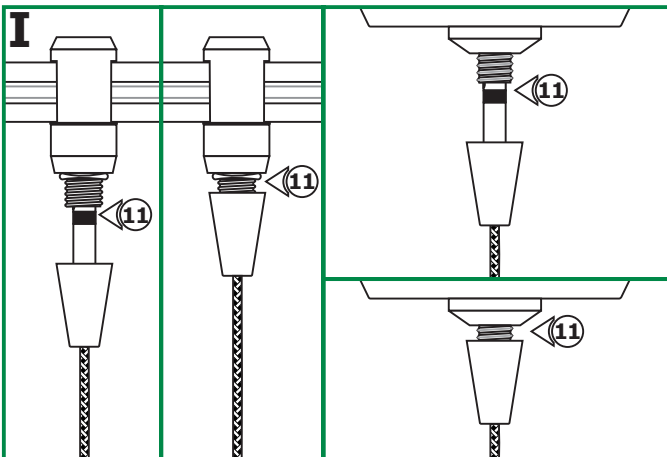

11: Use fingers to tighten the Fast Jack fixture connector into the Fast Jack system connector (Monorail, Monorail 2 Circuit, or canopy connector - Refer to the instructions provided with the system connector or canopy).

12: Refer to the instructions provided with the Monorail 2 Circuit fixture connector to choose Circuit #1 or Circuit #2.

