

Installation Instructions for Round Crystal

IMPORTANT INFORMATION

- This product is ETL listed for indoor dry locations.
- This product is wall mounted only and it should be installed as an up light (lamp facing up).
- This product can mount to either a 4" square electrical box with round plaster ring or an octagon electrical box.
- This product can be dimmed with a low voltage electronic dimmer.

SAVE THESE INSTRUCTIONS!

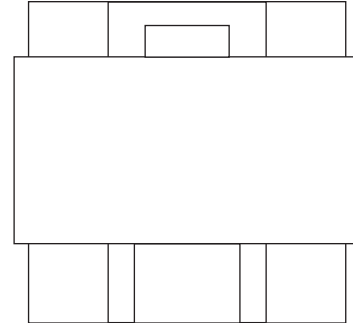

Install the Fixture

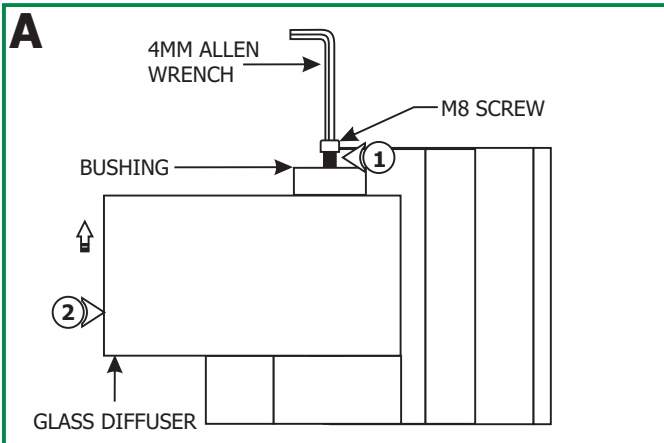

- 1: While holding the fixture remove the M8 screw on the bushing with the 4mm Allen wrench.
- 2: Remove the bushing from the threaded post (**Do Not Remove the Threaded post**) and pull the glass diffuser out.

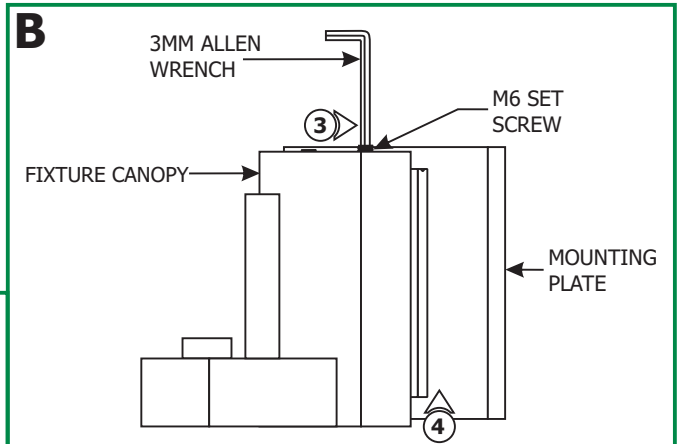

- 3: Loosen the two M6 set screws on the top of the fixture canopy (**Do Not Remove**) with the provided 3mm Allen wrench.
- 4: Pull the mounting plate out of the fixture canopy.

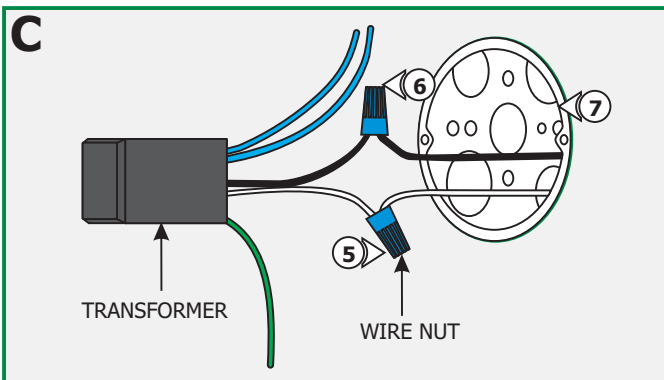

- 5: Connect the white transformer wire to the neutral power wire with a wire nut.
- 6: Connect the black transformer wire to the hot power wire with a wire nut.
- 7: Place the transformer and wire nut connections inside the electrical box.

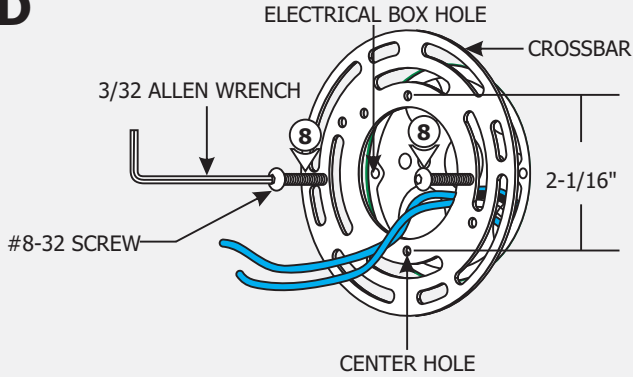
D

NOTE: The two center mounting holes (spaced 2-1/16" apart) on crossbar should be oriented vertically when mounting the crossbar to electrical box.

8: Mount the crossbar to the electrical box holes with the provided #8-32 screws using the 3/32 Allen wrench.

9: Make sure that the crossbar is grounded in accordance with local electrical codes.

10: Feed the transformer wires through the mounting plate center hole.

11: Align the mounting plate so that the grooved edge faces upward. Secure the mounting plate to the crossbar with the provided #8-32 screws using the 3/32 Allen wrench.

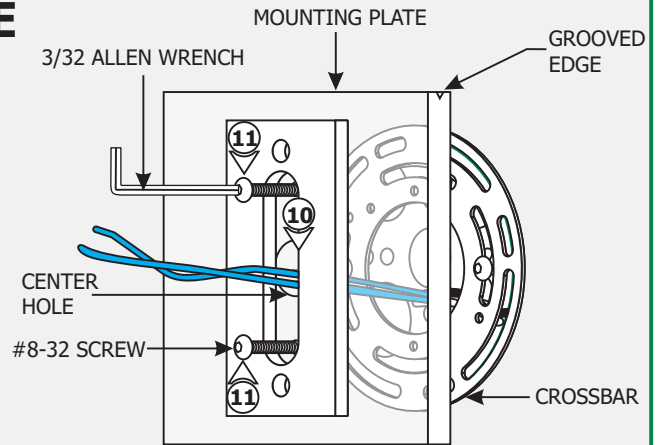
E

12: Connect each transformer low voltage wire (blue wire) to one fixture wire with a wire nut.

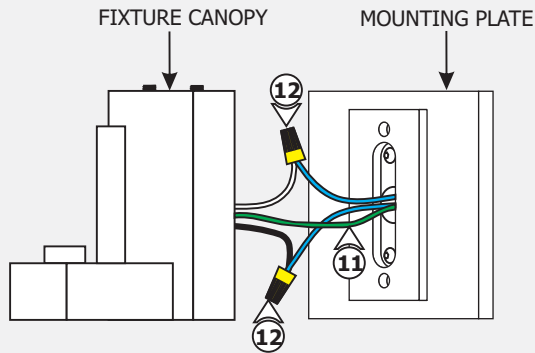
F

13: Place all wires and wire nut connections inside the fixture canopy.

14: Place the fixture canopy onto the mounting plate, and secure it by tightening the two M6 set screws with the 3mm Allen wrench.

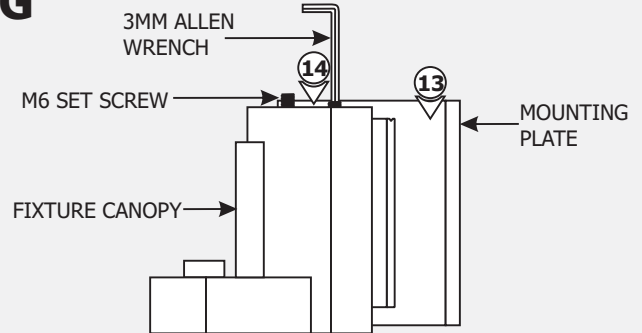
G

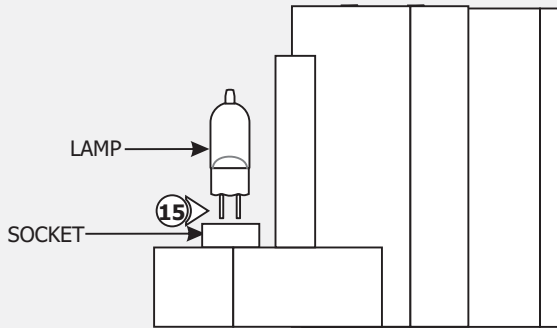
H**WARNING: RISK OF FIRE**

Never replace a Xenon (Xelogen) lamp with a regular Halogen lamp. A regular Halogen lamp requires a protective glass shield.

CAUTION: To reduce risk of a burn or electrical shock during lamping, disconnect the power to the fixture.

NOTE: Use only fingers and a soft cloth to install the lamps.

Use **MAX 35** Watt Bi-Pin Xenon (Xelogen) Lamp.

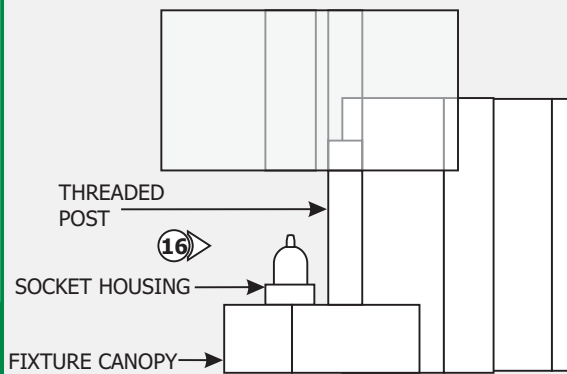

15: Push the lamp pins completely into the socket holes.

I

16: Slide the glass diffuser back hole onto the threaded post. Align the glass diffuser center hole with the socket housing and carefully rest the diffuser onto the fixture canopy.

17: Replace the bushing and M8 screw onto the threaded post. Tighten the M8 screw with the 4mm Allen wrench to secure the glass diffuser in place.

J