

Installation Instructions for **Twiggy Hinged 12V AC, Direct 1" with 4" Square Canopy**

IMPORTANT INFORMATION

- This instruction shows a typical installation.
- This product can mount to either a 4" square electrical box with round plaster ring or an octagon electrical box.

SAVE THESE INSTRUCTIONS!

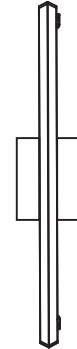

Install the Fixture

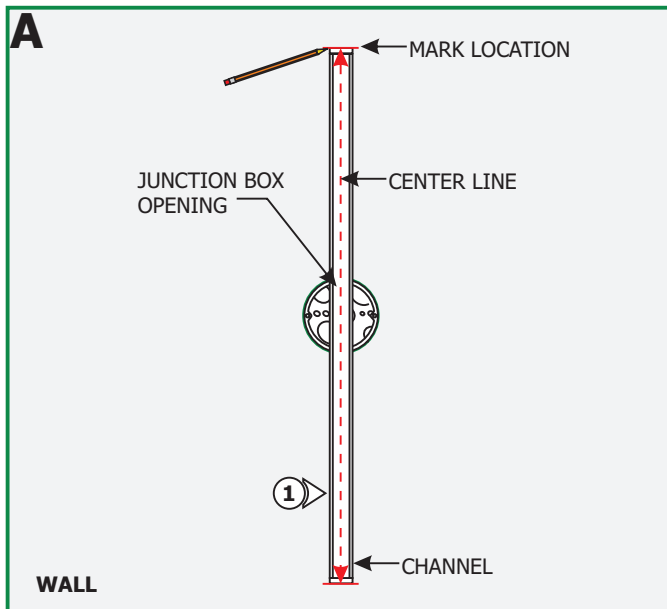

NOTE: It is recommended more than one person to assist in this installation.

NOTE: Fixture can be mounted in a horizontal or vertical position.

NOTE: Channel rotates in only one direction, so orientation must be determine before installing.

NOTE: The junction box does not need to be in middle of the channel (could be mounted from any end) but needs to be aligned in the center of the channel.

1: Center the channel to the junction box opening. Make markings to each end of the channel and also make a center line from end to end.

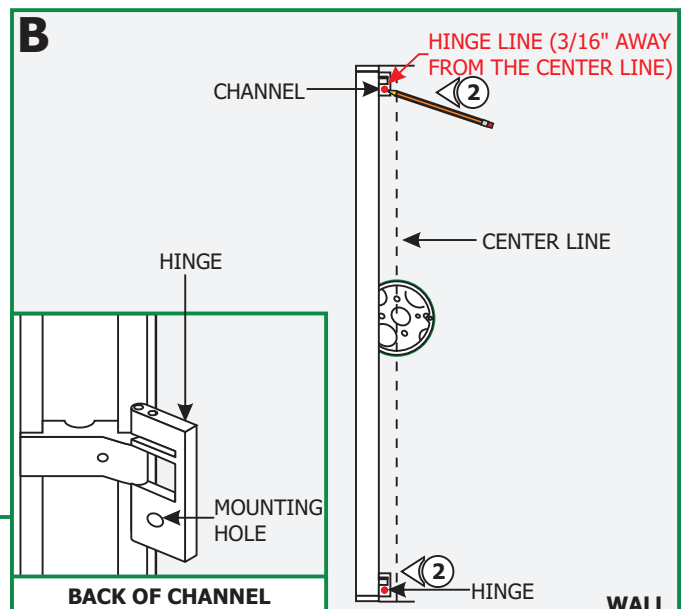

2: Unfold the channel hinges. Align the channel between the marked lines and mark the hinge holes 3/16" away from the center line.

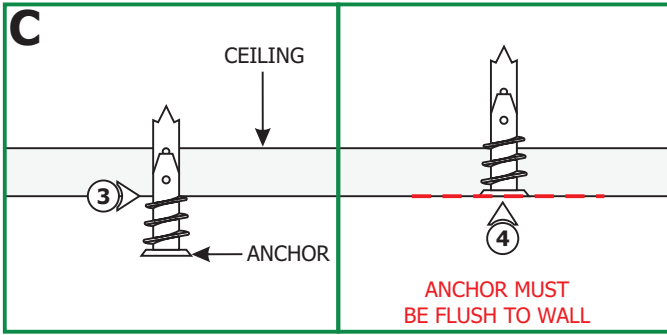

- 3:** Tap the anchors onto the marked points up to the threaded portion with a hammer.
- 4:** Screw in the threaded portion of the anchors with a Phillips screwdriver.

- 5:** Connect the white power supply wire to the neutral power wire with a wire nut.
- 6:** Connect the black power supply wire to the hot power wire with a wire nut.
- 7:** Place the power supply and wires inside the electrical box.

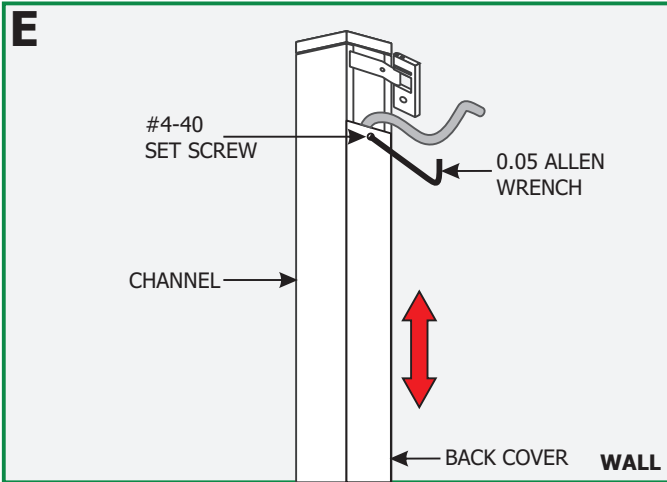
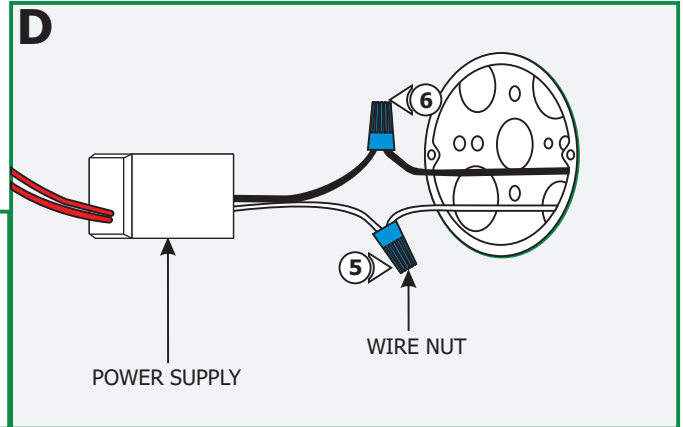

NOTE: If the junction box is located at one end of the channel, then loosen the #4-40 set screw with the 0.05 Allen wrench on one of the back cover moving the opening hole to one end. Pull the wire out of that end & retighten the #4-40 set screw with the 0.05 Allen wrench.

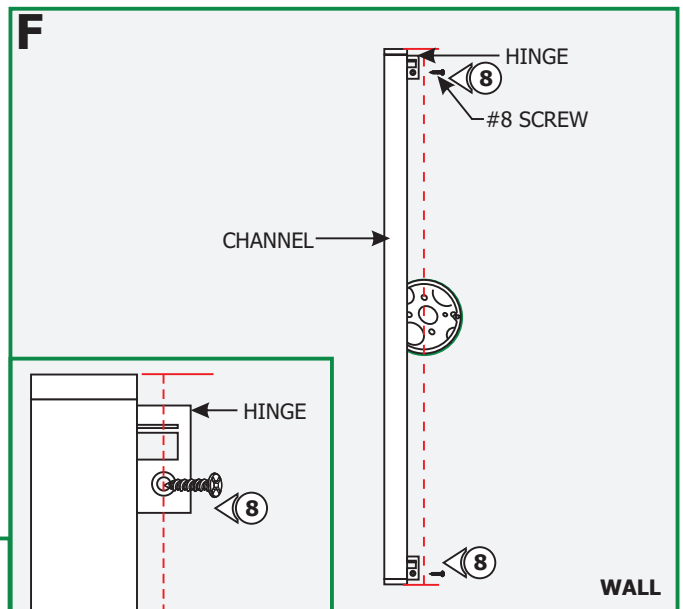

- 8:** Line up the hinge to the anchors and secure it by tightening the #8 screws to each hinge.

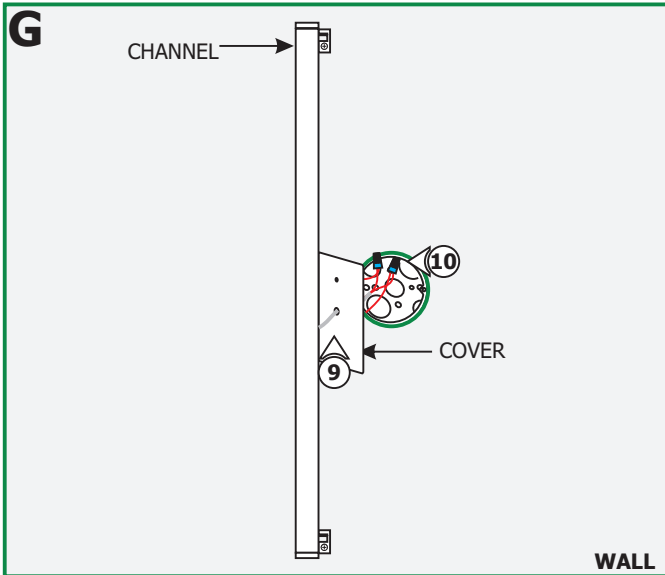

- 9:** Feed the channel wires through the cover center hole.
- 10:** Connect each power supply wire to a fixture body wire with a wire nut.
- 11:** Place the excess wires and wire nut connection inside the junction box.

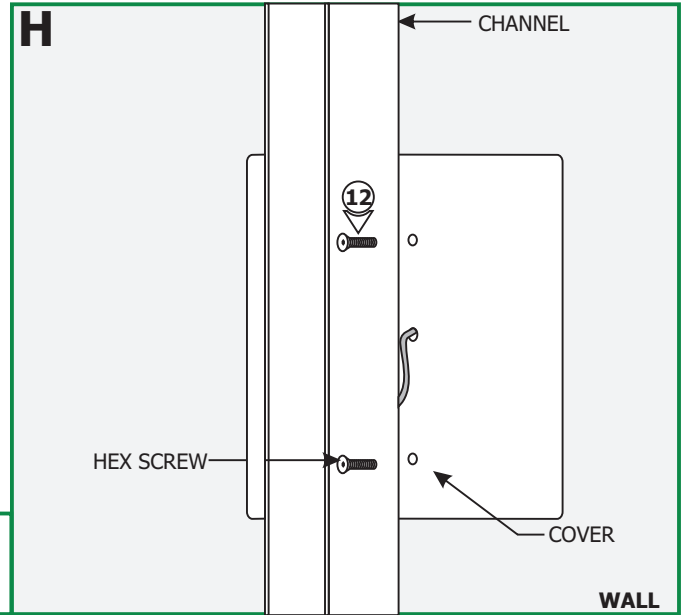

- 12:** Align the covers mounting holes to the junction box, and secure using the two hex screws with the provided Allen wrench.

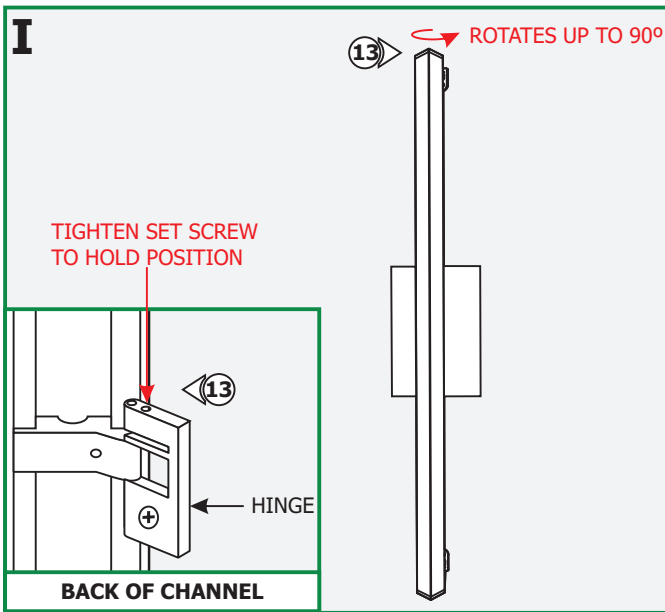

- 13:** Twiggly hinged rotates up to 90° degrees, and to hold the position, tighten the M2 set screw to each the hinge with a 0.9mm Allen wrench.

GENERAL WIRING DIAGRAM

