

Installation Instructions for Vega Round and Oval (Compact Fluorescent Version)

IMPORTANT INFORMATION

- This product is ETL listed for indoor locations.
- This product can **ONLY** be ceiling mounted.
- This product can mount to either a 4" square electrical box with round plaster ring or an octagon electrical box.

SAVE THESE INSTRUCTIONS!

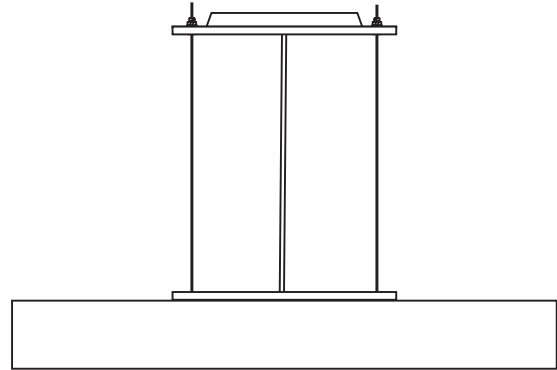

Adjust the Fixture Height

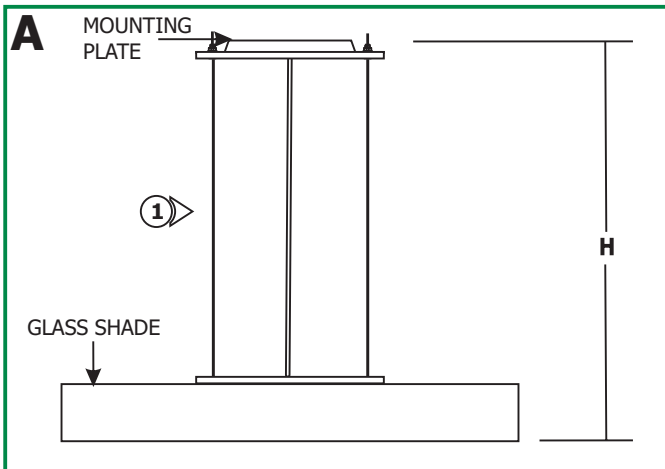

1: Determine the desired fixture height (**H**), from the bottom of the glass shade to the top the mounting plate.

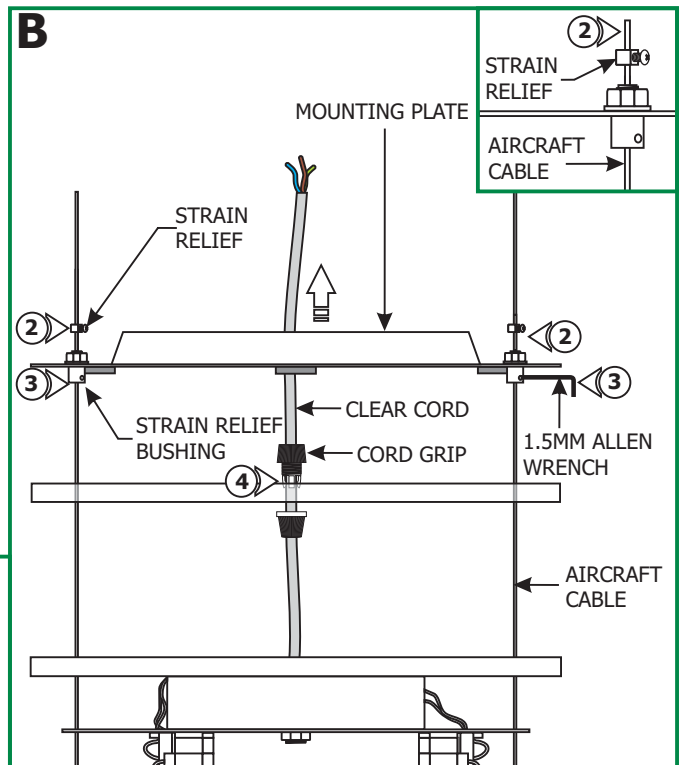

2: Loosen the Phillips screw on each of the strain reliefs (**Do Not Remove**).

3: Loosen the set screws on the strain relief bushings with the provided 1.5mm Allen wrench.

4: Loosen the cord grip to adjust the clear cord.

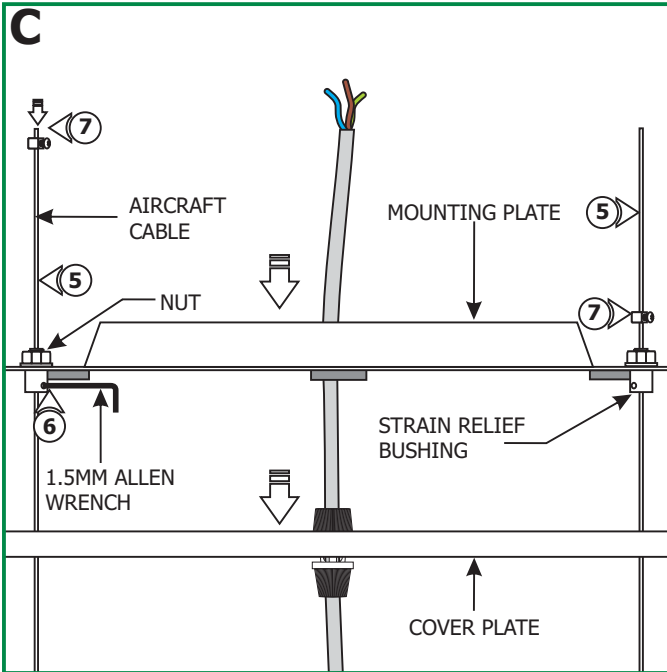

- 5:** While holding the aircraft cables, slide the mounting plate, cover and the socket assembly down until the desired height is achieved.
- 6:** Tighten the set screw on each strain relief bushing with the 1.5mm Allen wrench.
- 7:** Slide the strain relief down the aircraft cable against the mounting plate and tighten the Phillips screw. Repeat this step for the remaining strain relief.

- 8:** Cut the excess aircraft cables off with a sharp cutter (Leave at least 3" of the cable behind the strain reliefs).
- 9:** Pull the excess clear cord through the mounting plate and tighten the cord grip.

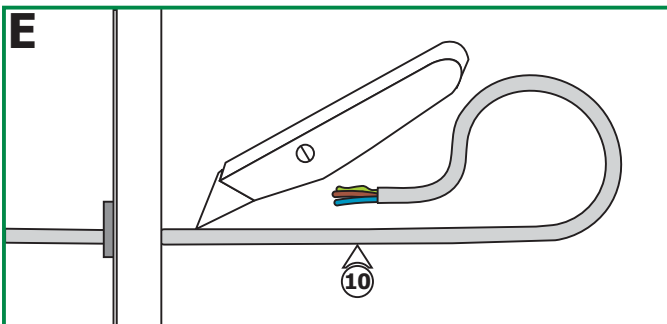
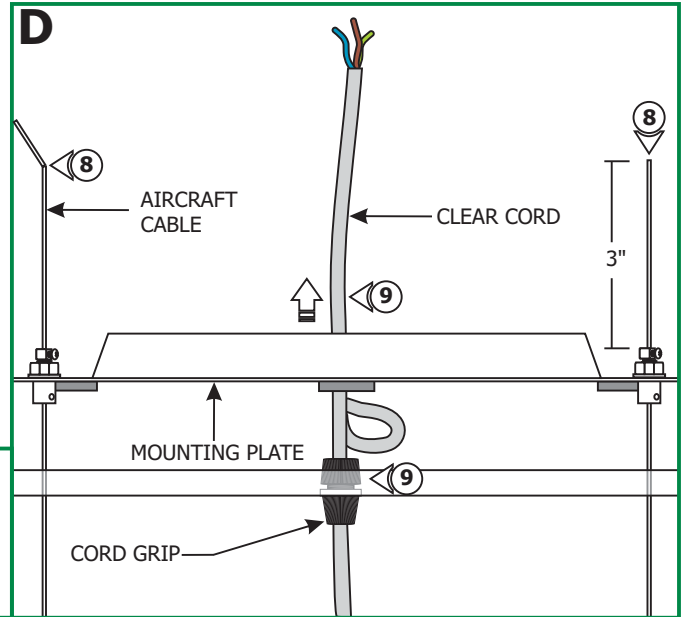

- 10:** From the end of the clear cord, strip the outer insulation using a sharp knife. **Make sure not to nick the inner wires and trim off the cutout insulation.**

- 11:** Leave 6" of the wire behind the mounting plate for power connection. Trim off the excess wires.

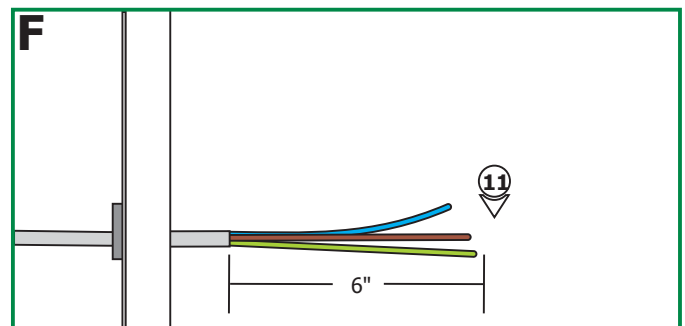

Install the Fixture

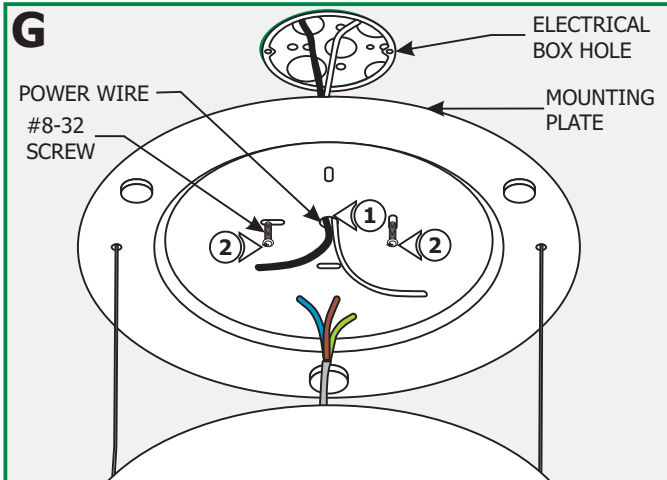

NOTE: Make sure the glass shade is detached.

NOTE: Use the provided universal crossbar if the mounting plate holes do not line up with the electrical box holes.

- 1:** Feed the power wires through the mounting plate center hole.
- 2:** Secure the mounting plate to the electrical box holes with the two #8-32 screws provided.

- 3:** Make sure the mounting plate and the bare wire is grounded in accordance with local electrical codes.
- 4:** Connect the blue wire to the neutral power wire with a wire nut.
- 5:** Connect the brown wire to the hot power wire with a wire nut.

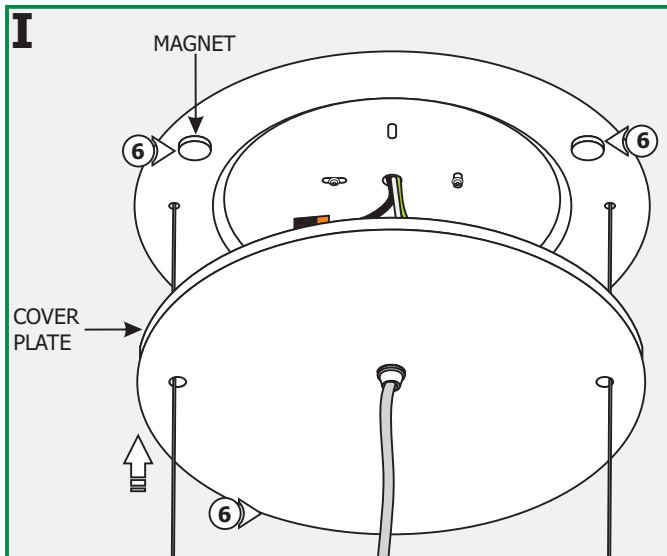
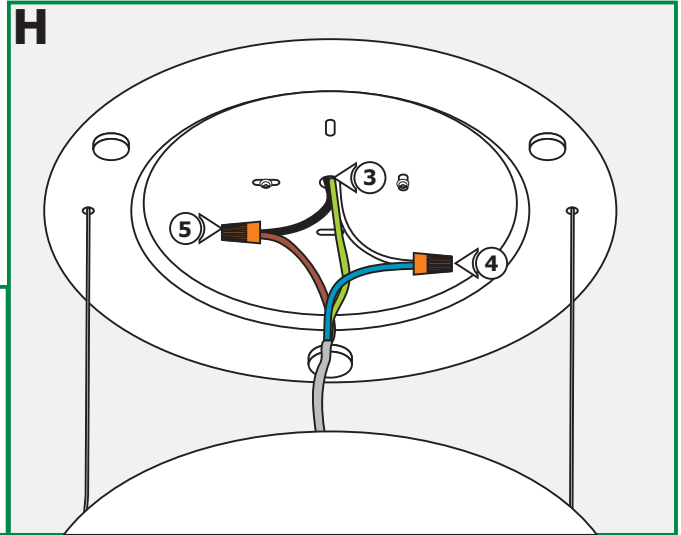

- 6:** Slide the cover plate up against the mounting plate, the magnets will hold the cover plate in place.

Install the Lamps and Shade

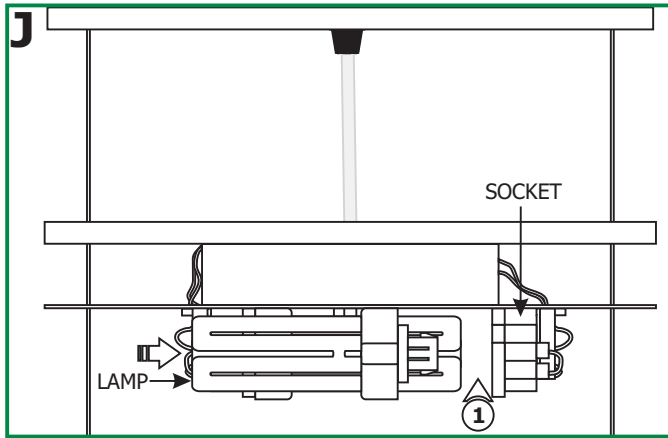

CAUTION: To reduce risk of a burn or electrical shock during lamping, disconnect the power to the fixture.

Use **MAX 26** Watt Type GX24q-3 Base Compact Fluorescent Lamp With Each Socket For VEGA-F1- models.

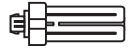

Use **MAX 32** Watt Type GX24q-3 Base Compact Fluorescent Lamp With Each Socket For VEGA-F2- models.



1: Push the lamp pins completely into the socket holes.

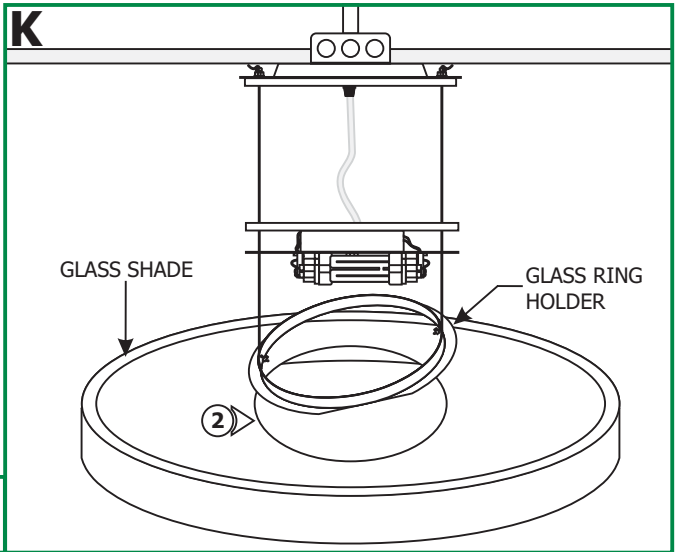

2: Insert the glass ring holder on an angle into the glass shade center hole and lay the glass shade on the glass ring holder.

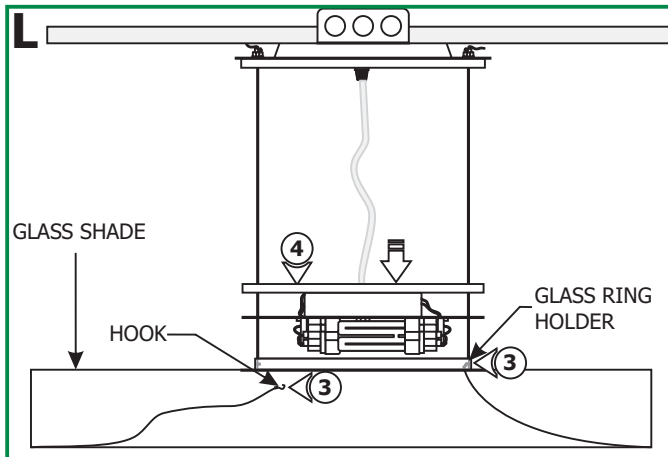

3: To secure the glass shade in place, use the hooks inside the glass shade and hook them to the inside of the glass ring holder.

4: Lower the socket assembly into the glass shade.

5: If the glass shade is not level horizontally, slide the cover plate down to expose the mounting plate.

6: Readjust the uneven aircraft cable by loosening the set screw on the strain relief bushing with the 1.5mm Allen wrench. Push the aircraft cable in and re-tighten the set screw.

7: Slide the cover plate up against the mounting plate.

