

Installation Instructions for Step LED Kit

IMPORTANT INFORMATION

- This product is ETL listed for indoor dry locations.
- This fixture is wall mount only.

SAVE THESE INSTRUCTIONS!

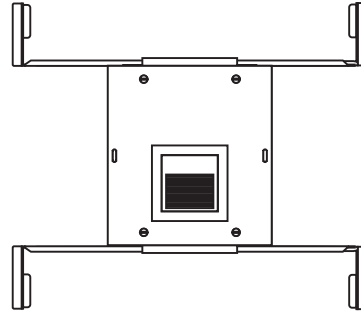

Install the Step Housing

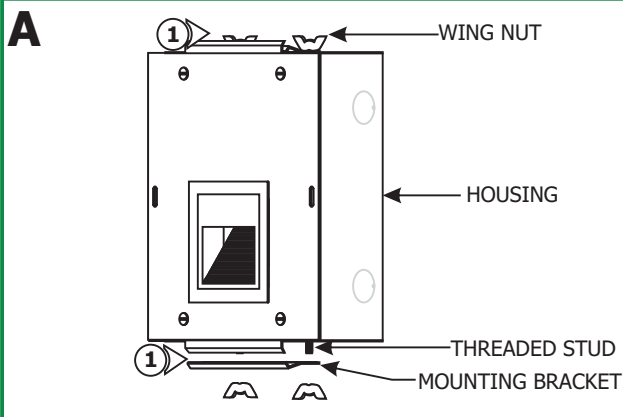

- 1:** Loosen the two top and bottom wing nuts on the housing to remove the two mounting brackets.

- 2:** Mount one adjustable mounting bar to the top of the housing by sliding it completely under the housing lip.

- 3:** Replace the mounting bracket onto the threaded studs so that the flange faces the adjustable mounting bar. Tighten the wing nuts to secure the adjustable mounting bar in place.

- 4:** Repeat steps 2 and 3 for the bottom of the housing.

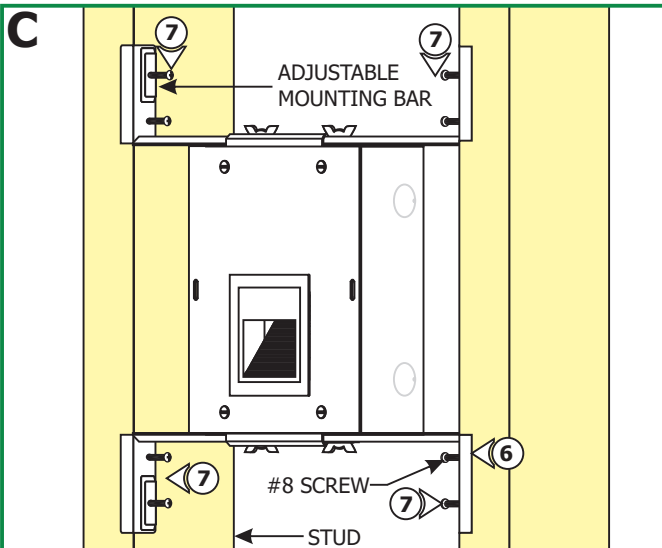
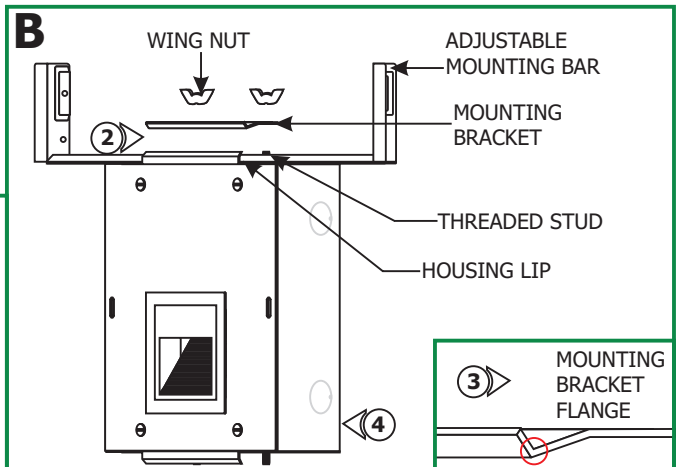

NOTE: The adjustable mounting bars mount to studs that are spaced 16" to 24" apart.

- 5:** Select the location between the two studs for the housing to be mounted.

- 6:** Place the adjustable mounting bars between the studs.

- 7:** Make sure the lips on the adjustable mounting bars are against the studs. Secure the adjustable bars to the studs with the provided eight #8 screws.

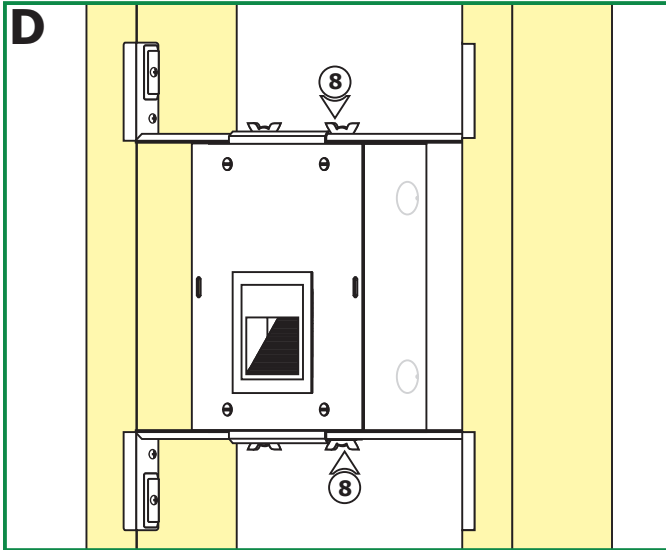

8: Slide the housing to desired position. If necessary loosen the wing nuts to ease the sliding. After the desired position is achieved tighten all the wing nuts.

9: Loosen the four #8-32 screws on the front of the housing.
10: Remove the trim and cover from the housing.

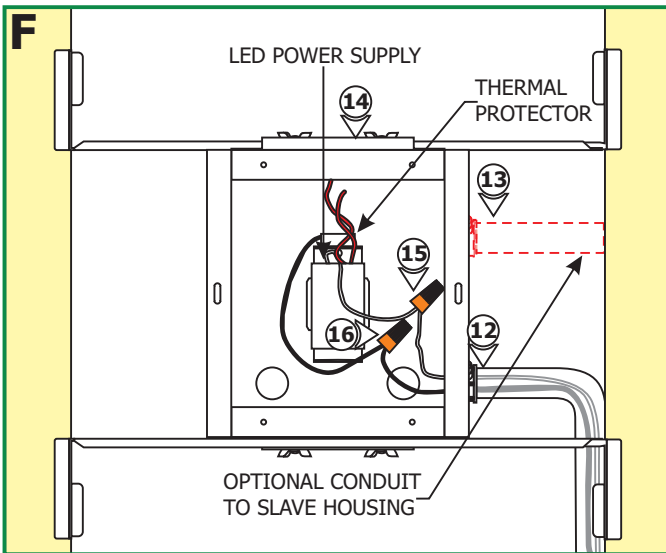
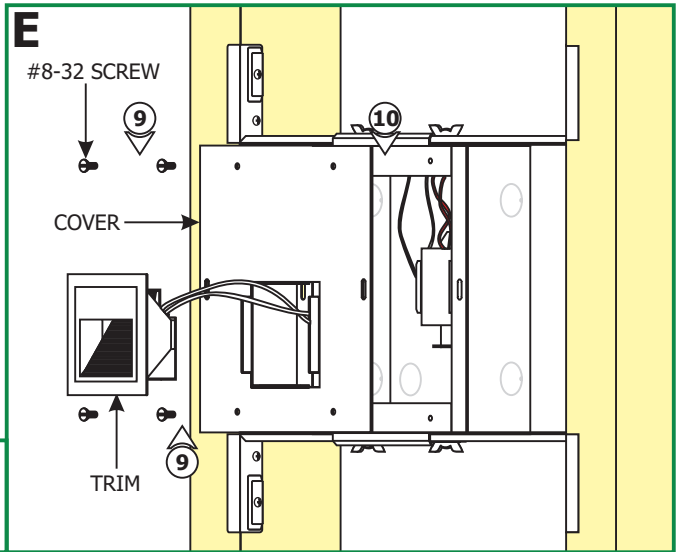

11: Remove a knock out to install the power line conduit.
12: Install the conduit and run the power line wires to the housing.
13: (OPTIONAL)-If using slave housings (Maximum 25 Slave Housings), repeat step 1 through 10 on pages 1 and 2 for each slave housing; run conduits for the low voltage wires in sequence from the master housing and slave housing to the adjacent slave housing.

NOTE: Maximum 25 Slave step kits can be powered from a master step kit. It is recommended to install the master step kit in the middle of the run powering the slaves on both sides to reduce voltage drop. The last step slave kit should not be more than 20ft away from the master kit.

14: Make sure that the housing is grounded in accordance with local electrical codes.
15: Connect the LED power supply white wire to the power line neutral wire with a wire nut.
16: Connect the LED power supply black wire to the power line hot wire with a wire nut.
17: If using slave housings, then follow the "Slave Step Kit Wiring" steps; otherwise follow "Install the Drywall, Trim & Lamp" steps on page 4.

LOW VOLTAGE WIRE SIZE CHART

POWER SUPPLY WATTAGE	WIRE SIZE FOR UP TO 13 FT	WIRE SIZE FOR 14-20 FT	WIRE SIZE FOR 21-34 FT	WIRE SIZE FOR 35-52 FT
60 WATT	#14 GA	#12 GA	#10 GA	#8 GA

Slave Step Kit Wiring

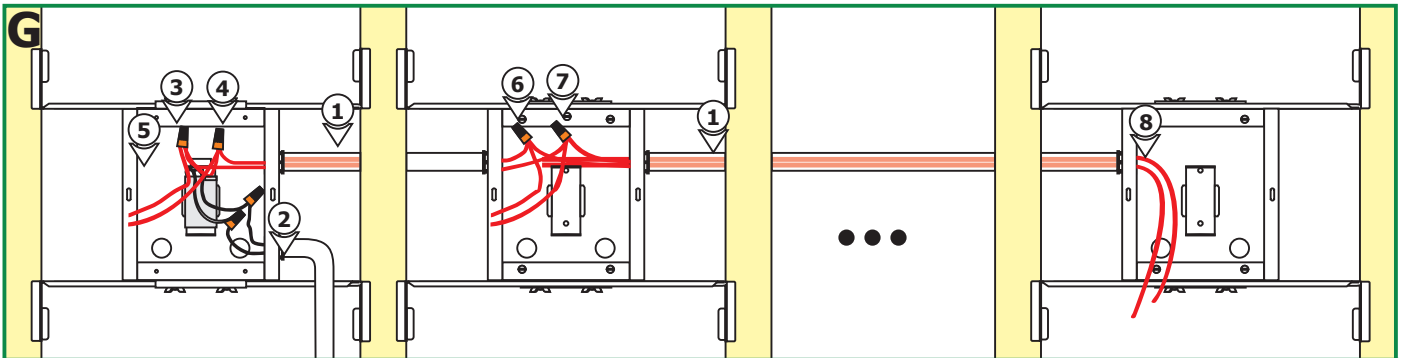
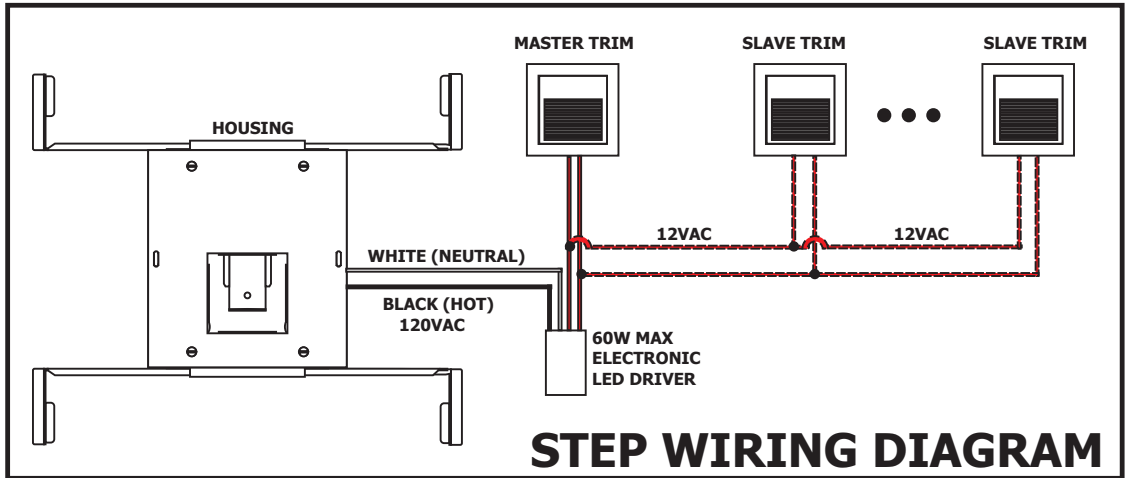

- 1:** Run the proper low voltage wires to each housing by referring to the "Low Voltage Wire Size Chart" on page 2. The distances are from the master housing to each slave housing. Refer to the wiring diagram above before proceeding with the steps below.
- 2:** Make sure the power to the LED power supply line voltage wires are off.
- 3:** Starting with the master housing, connect one LED power supply wire to one low voltage (12VAC) wire going to adjacent slave housing and to a 1 foot long low voltage pigtail wire with a wire nut.
- 4:** Connect the other LED power supply wire to the other low voltage (12VAC) wire going to the adjacent slave housing and another 1 foot long low voltage pigtail wire with a wire nut.
- 5:** Continuing with the adjacent slave housing, connect one of the low voltage (12VAC) wires coming from the preceding housing to a low voltage (12VAC) wire going to next slave housing and to a 1 foot long low voltage pigtail wire with a wire nut.
- 6:** Connect the other low voltage (12VAC) wire coming from the preceding housing to the other low voltage (12VAC) wire going to the next slave housing and to a 1 foot long low voltage pigtail wire with a wire nut.
- 7:** Repeat steps 4 through 6 for all other slave housing except the last one.
- 8:** Make sure the low voltage (12VAC) wires coming from preceding housing to the last housing extends 1 foot out of the slave housing.

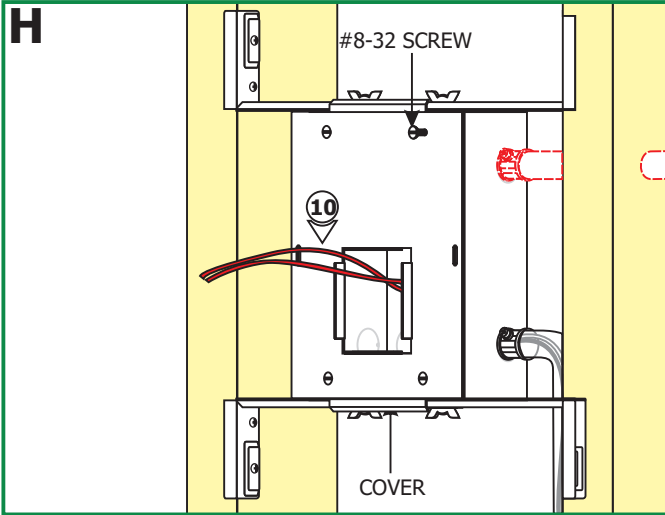

9: Feed the pigtail wires through the cover hole and mount to cover to the housing with the four #8-32 screws.

10: Repeat step 9 for the remaining housings.

Install Drywall, Trim & Lamp

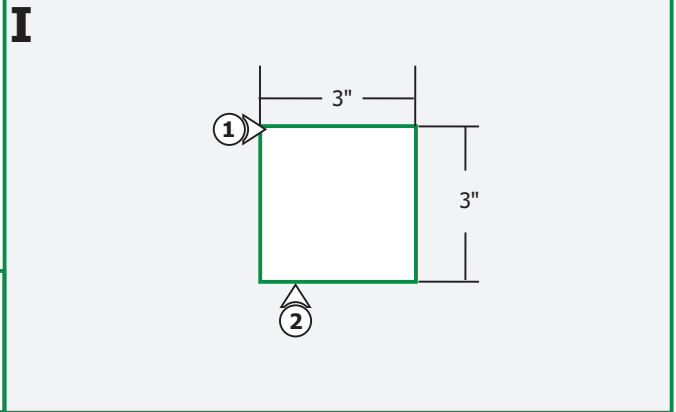

1: Mark 3" square(s) on drywall where the housing opening is (are) located.

2: Cut out the marked square(s) and install the drywall.

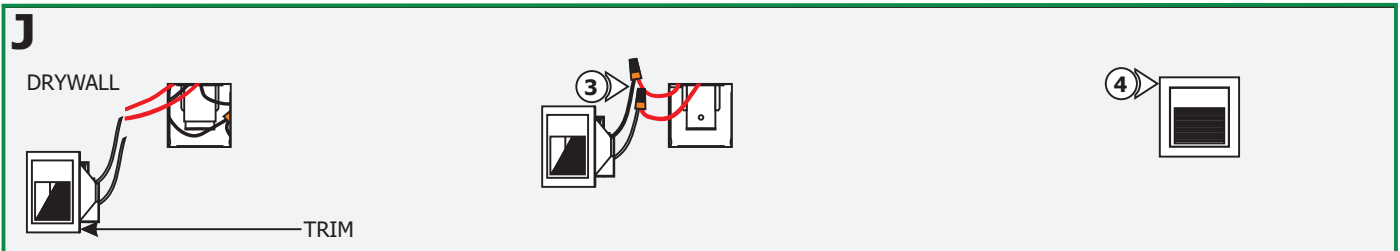

3: After installing drywall and finishing it, connect each wire coming out of the housing opening to one trim wire with a wire nut.

4: Place all wires inside the housing and gently push the trim into the housing opening by squeezing the side springs.

5: (Optional) - If slave housings are used, then repeat steps 3 and 4 for all slave housings.

NOTE: Each fixture contains a 2 watt integrated LED lamp. These lamps are rated for 40,000 hours.