

Mini Delaware

600FJMDLW

1.1



GENERAL PRODUCT INFORMATION:



This product is ETL listed and suitable only for indoor dry locations and approved for use at any height above the finished floor.

This product is patented (U.S. PAT. 6,183,297).

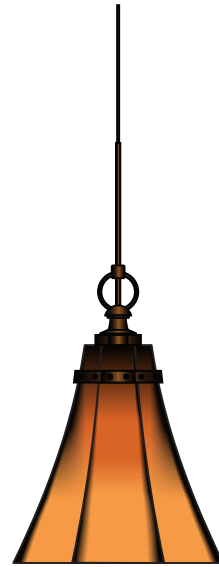

Adjust The Fixture Height

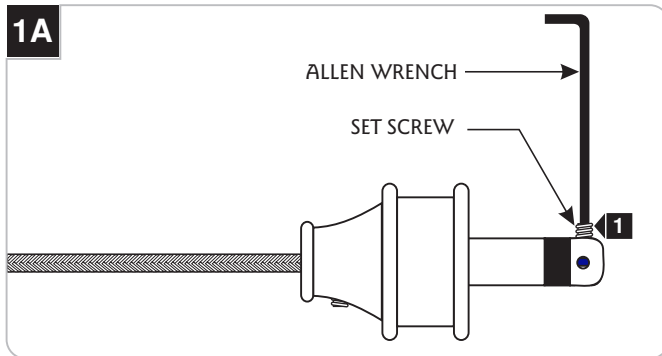

1 Back out (do not remove) the set screw on the tip of the connector with the provided Allen wrench.

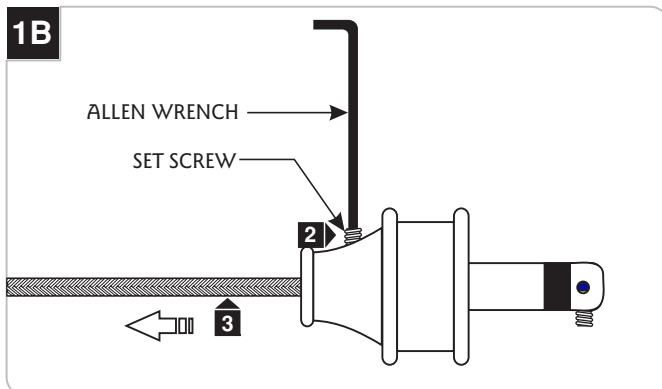

2 Back out (do not remove) the set screw on the connector with the provided Allen wrench.

3 Pull the coaxial cable out.

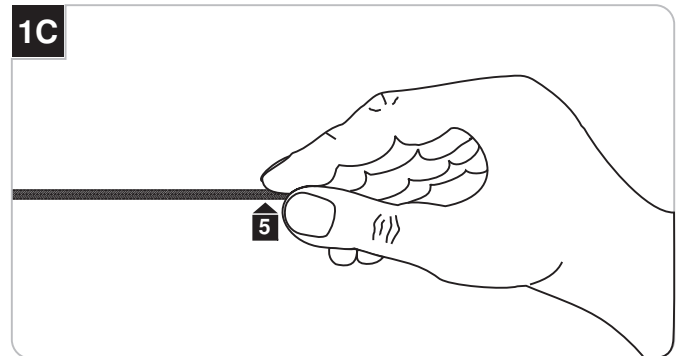

4 Cut the coaxial cable to the desired length.

5 Gently twist the end of the coaxial cable between thumb and forefinger.

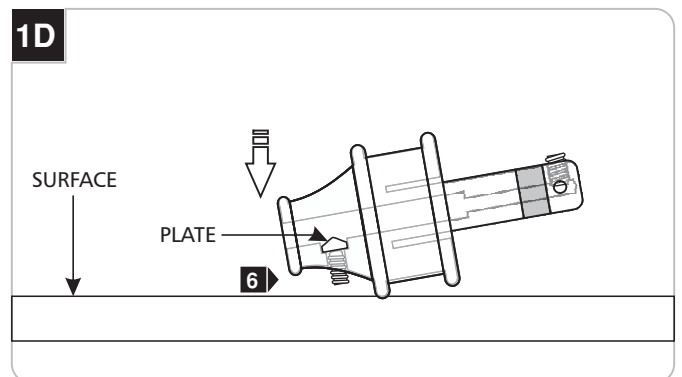

6 Tap the connector on a hard surface with the set screw facing down, so the plate inside drops into place.

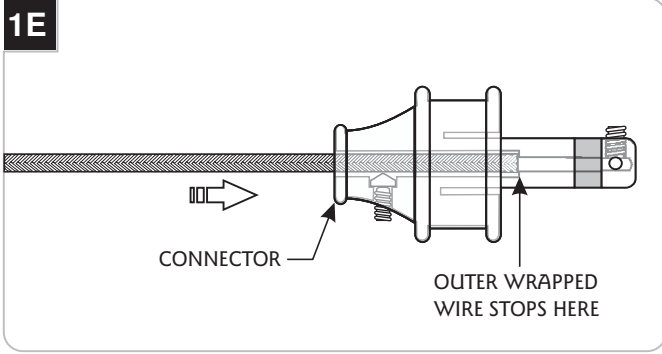

7 Feed and push the coaxial cable into the connector. The coaxial cable will come to a stop point after being inserted 3/4" into the connector.

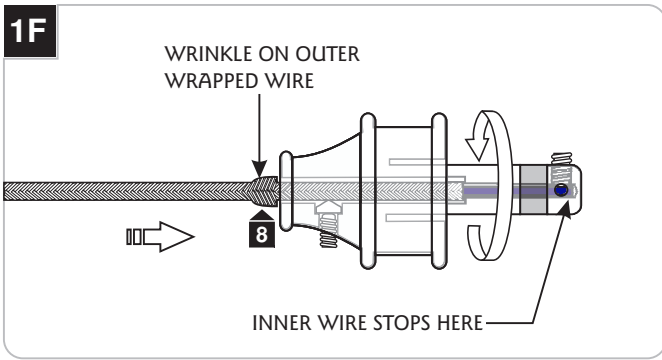

8 Keep pushing the coaxial cable into the connector while rotating the connector to ease feeding the inner wire into the tip of the connector. The outer wrapped wire will start wrinkling while being inserted another 1/2" into the connector.

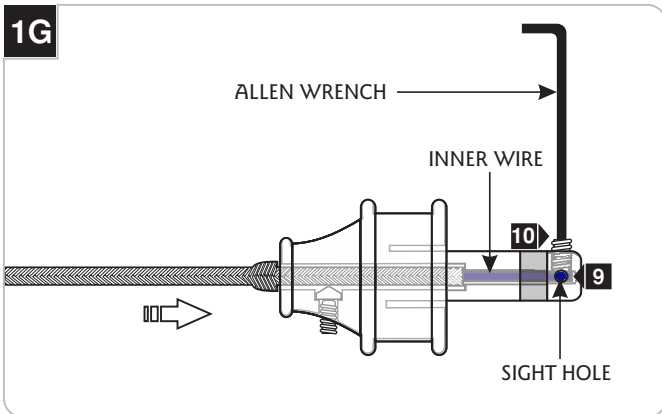

9 Look into the sight hole on the top of the connector to make sure that the inner wire is contacting the end of the connector.

10 Hold the coaxial cable in place and tighten the set screw on tip of the connector with the provided Allen wrench. **Make sure this set screw connection is tight.**

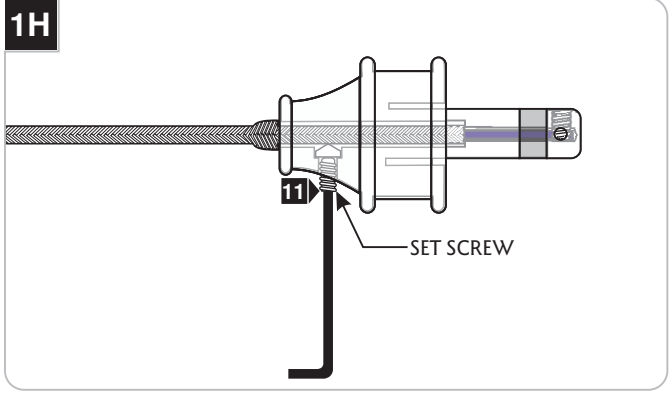

11 Firmly tighten the set screw on the connector.

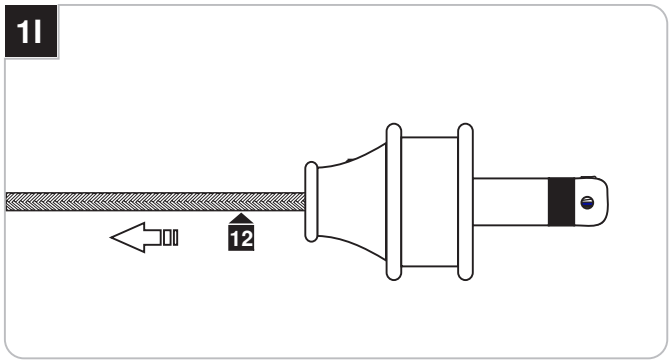

12 Pull the coaxial cable toward the fixture to smooth the wrinkles.

Replacing the Lamp

2A

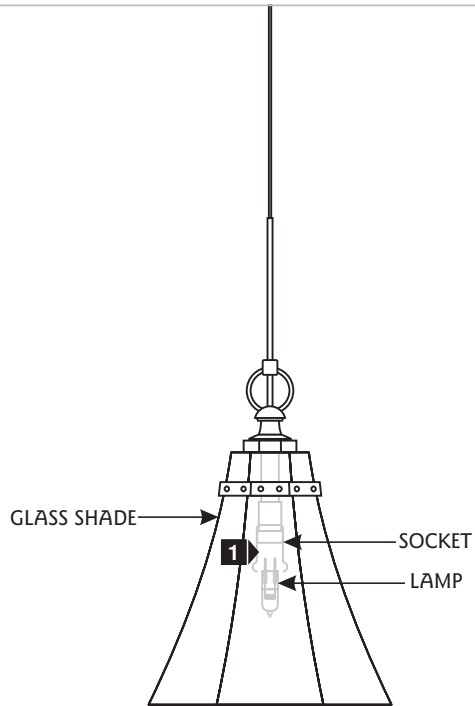

NOTE: To reduce the risk of a burn or electric shock during relamping, disconnect the power to the fixture.

NOTE: Use only your fingers and a soft cloth to replace the lamp.

Use **MAX** 50 Watt, Bi-Pin Halogen Lamp.



1 ▶ Gently insert the lamp pins into the socket holes.

2B

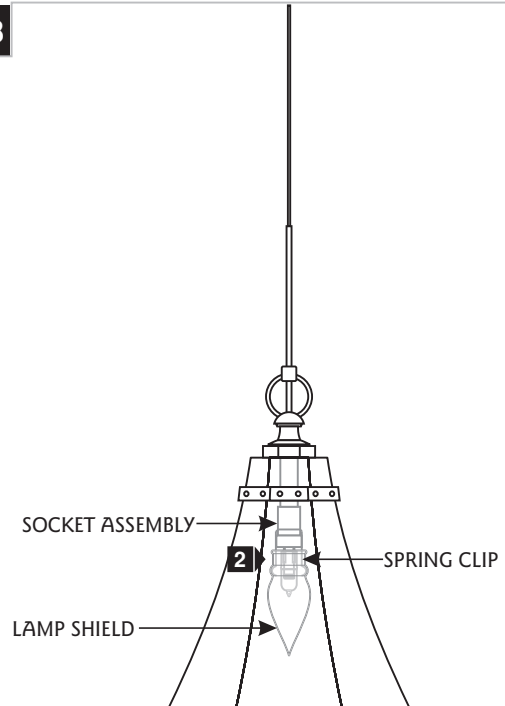

2 ▶ Push the lamp shield onto the spring clip.

IMPORTANT SAFETY INSTRUCTIONS

To reduce the risk of fire, electrical shock, exposure to excessive UV radiation, or injury to person:

- Use this fixture indoors only.
- Do not look directly at the lighted lamp.
- Do not remain in light if skin feels warm.
- Risk of fire: Use only the type of lamp and maximum wattage indicated in this instruction manual.
- Never cover the halogen lamp with anything other than a Tech Lighting lamp shield and never place flammable material close to your fixture.
- Do not touch the fixture shades or lamp shield while the fixture is on. These surfaces may be HOT.
- To avoid glare in child's eyes, hang the fixture at least 18" above a table.

Halogen Lamp General Information

- It is normal for a new halogen lamp to smoke slightly on first use. The protective coating is being vaporized.

Prolonging Halogen Lamp Life

- Do not touch the lamp with bare hands. Any contaminant, even the oil from your hands can deteriorate the lamp. Handle the lamp with a soft, clean cloth. Rubbing alcohol can be used to remove any contaminant from the lamp.
- Do not run the lamps at full power when you do not need to. However, if dimming the fixture for an extended period of time, occasionally bring the light up to full brightness for a few minutes to complete the halogen cycle.

SAVE THESE INSTRUCTIONS!



7400 Linder Ave, Skokie, IL 60077
847.410.4400

www.wilmettelighting.com

© 2008 Wilmette Lighting Company. All rights reserved. The "Wilmette Lighting Company" graphic is a registered trademark of Wilmette Lighting Company. Wilmette Lighting Company reserves the right to change specifications for product improvements without notification.

A Generation Brands Company